

XYR 6000 Wireless High Level Analog Input Transmitter Model STIW600

0 to 5 Volts
1 to 5 Volts
0 to 20 mA
4 to 20 mA

Specification and Model Selection Guide

Introduction

Building upon the tremendously successful ST 3000 series transmitter line; Honeywell brings simple, safe, and secure wireless technology to its measurement portfolio in the XYR 6000 Series Wireless Transmitters.

The XYR 6000 series measurements are part of the Honeywell OneWireless system and are ISA100.11a Compliant.

Measurement and information without wires! The XYR 6000 wireless transmitter series enable customers to obtain data and create information from remote and hazardous measurement locations without the need to run wires, where running wire is cost prohibitive and/or the measurement is in a hazardous location. Without wires, transmitters can be installed and operational in minutes, quickly providing information back to your system.

XYR 6000 wireless transmitters send information to an ISA100.11a compliant MESH infrastructure. Wireless Data Managers (WDM) provides the path to bring that information into Experion PKS or any other control system wirelessly via OPC client or Modbus-TCP.

Transmitter power is supplied by two "D" size lithium batteries in an intrinsic safe module with an expected lifetime of up to ten years or by an external 24 Vdc power supply. Transmitter range with the integral antenna is 1000' (305 m) under ideal conditions.

The HLAI Transmitter can be used to convert any measurement device with a 4-20mA/1-5 V output into a wireless sensor; for example, analytical, flow, or level measurements. The HLAI can be used with measurement devices that have Intrinsic Safety approval to make a wireless measurement while retaining the Intrinsic Safety rating.

Only 0/4 to 20 mA inputs are certified as Intrinsically Safe. 0/1 to 5 V inputs are not certified as Intrinsically Safe.



Figure 1—XYR 6000 High Level Analog Input Transmitters

Implement the value of wireless technology today:

- Measure remote access points simply, safe and securely
- Obtain and utilize previously inaccessible information due to high wiring cost or hazardous locations.
- Easily meet Regulatory Requirements
- Improve process efficiency
- Enhance Flexibility to monitor applications:
 - that have no access to power
 - that are remote or difficult to reach
 - that may require frequent reconfiguration
 - where manual readings have been required previously.

Specifications

Operating Conditions

Parameter	Reference Condition (at zero static)		Rated Condition		Operative Limits		Transportation and Storage	
	°C	°F	°C	°F	°C	°F	°C	°F
Ambient Temperature**	25 ±1	77 ±2	-40 to 85*	-40 to 185*	-40 to 85*	-40 to 185*	-40 to 85	-40 to 185
Humidity %RH	10 to 55		0 to 100		0 to 100		0 to 100	
Ambient Temperature LCD Display visible range	25 ±1	77 ±2	-40 to 85°C -40 to 185°F					
Vibration	Maximum of 4g over 15 to 200Hz.							
Shock	Maximum of 40g.							
Power	Battery powered 3.6V Lithium thionyl chloride (LiSOCl ₂) batteries non rechargeable, size D							
	24VDC Wired Power (option) - For I.S. Application: 21 V to 25 Vdc Operated with MTL7728P+ barrier (252 Ohms Max. end to end resistance), Max input current 26mA. For Non I.S. application: 11 V to 30 Vdc Input range, Max input current 100mA.							

*24V power option rated 80°C (176°F)

** The Ambient Limits shown are for Ordinary Non-Hazardous locations only. Refer to the appropriate Control Drawing, FM/CSA, ATEX, or IECEx for the Ambient Limits when installed in Hazardous Locations.

Wireless Specifications

Parameter	Description
Wireless Communication	2,400 to 2,483.5 MHz (2.4 GHz) Industrial, Scientific and Medical (ISM) band FHSS Selection – Frequency Hopping Spread Spectrum DSSS Selection – Direct Sequential Spread Spectrum per FCC 15.247 / IEEE 802.15.4–2006. ISA100.11a Compliant (2.4 GHz Direct Sequence Spread Spectrum 802.15.4 DSSS-FH) Every data packet transmitted in either direction is verified (CRC check) and acknowledged by the receiving device. USA – FCC Certified Canada – IC Certified European Union – RTTE/ETSI Conformity Japan – Ministry of Internal Affairs and Communications Certified (DSSS Selection only)
ISA100.11a RF Transmitter Power (Optional)	NA Selection – 125 mW (20.9 dBm) maximum transmit power not including antenna per FCC/IC, or 400 mW (26.0 dBm) maximum EIRP including antenna for USA and Canadian locations. EU Selection – 10 mW (10.0 dBm) maximum EIRP including antenna per RTTE/ETSI for EU locations.
FHSS RF Transmitter Power (Optional)	NA Selection – 125 mW (20.9 dBm) maximum transmit power not including antenna per FCC/IC, or 400 mW (26.0 dBm) maximum EIRP including antenna for USA and Canadian locations. EU Selection – 100 mW (20.0 dBm) maximum EIRP including antenna per RTTE/ETSI for EU locations.
DSSS RF Transmitter Power (Optional)	NA Selection – 125 mW (20.9 dBm) maximum transmit power not including antenna per FCC/IC, or 400 mW (26.0 dBm) maximum EIRP including antenna for USA and Canadian locations. EU Selection – 10 mW (10.0 dBm) maximum EIRP including antenna per RTTE/ETSI for EU locations. JP Selection – 12.14 dBm/MHz [32mW (15.14 dbm)] maximum EIRP including antenna for Japanese locations.
Data	PV Publish Cycle Time: Configurable as 1, 5, 10 or 30 seconds Rate: 250 Kbps

Antennas	<p>Integral – 2 dBi omnidirectional monopole</p> <p>Integral – 4 dBi omnidirectional monopole</p> <p>Remote – 8 dBi omnidirectional monopole with up to 20 m cable and lightning surge arrester.</p> <p>Remote – 14 dBi directional parabolic with up to 20 m cable and lightning surge arrester.</p>
Signal Range	<p>Nominal 305 m (1,000 feet) between Field Transmitter and Infrastructure Unit (Multinode) or Gateway Unit when using 2 dBi Integral antenna with a clear line of sight.*</p> <p>Two XYR 6000 transmitters both having TX Power set to 16 dBm with a clear line of site nominal signal range is 150 m (490ft.)</p>
Routing vs Non-Routing	<p>Unit can be set as a Field Routing or non-Field Routing device; the number of routing devices is set by the system manager.</p> <p>Using the device as a routing device will impact battery life, the more messages routed through a device, the greater the impact on battery life.</p>

* Actual range will vary depending on antennas, cables and site topography.

Remote antenna cables

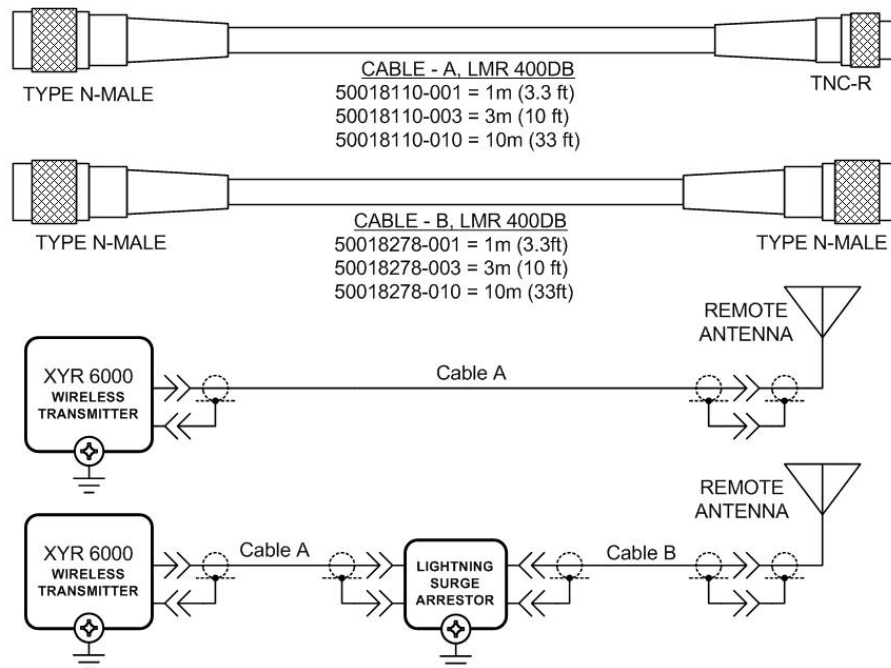

CABLE PARAMETERS			LIGHTNING SURGE ARRESTOR PARAMETERS
CABLE A, B LENGTH	CAPACITANCE	INDUCTANCE	
1 m	78.4 pF	0.2 μH	CAPACITANCE = 1 pF INDUCTANCE = 10 nH
3 m	235.2 pF	0.6 μH	
10 m	784 pF	2.0 μH	

Remote Antennas

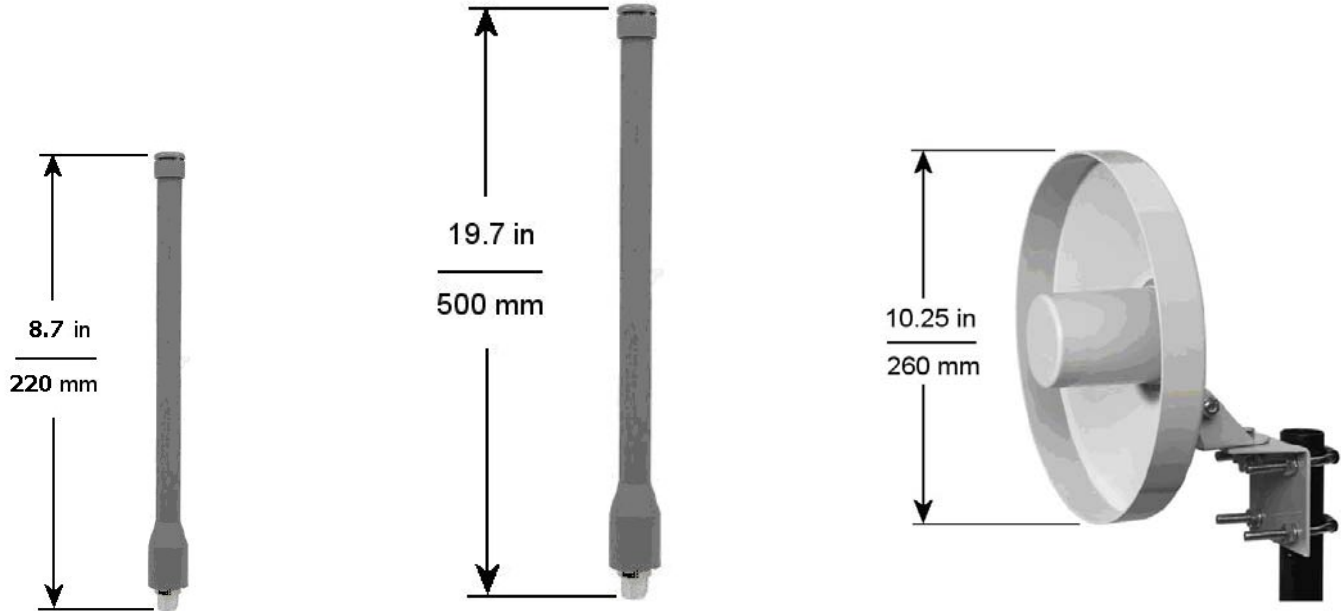

4 dBi Omnidirectional Antenna

8 dBi Omnidirectional Antenna

14 dBi Directional Antenna

Performance under Rated Conditions

Parameter	Description
Accuracy	±0.10% of range at reference conditions for linear inputs
Temperature Effects	±0.10% of range per °C
Stability	±0.10% of URL per year
Stray Rejection	<i>Common Mode</i> (50 or 60 Hz): 120 dB <i>Normal Mode</i> (50 or 60 Hz): 40 dB
Loop Resistance 0-20/4-20 mA input	24.9 Ohms
Lightning Surge Arrester (Remote antenna only)	Frequency range: 0 – 3 GHz, 50 Ohms, VSWR = 1:1.3 Max, Insertion Loss = 0.4 dB Connectors Type N Female, Max, Gas Tube Element: 90 V ± 20%, Impulse Breakdown Voltage = 1,000 V ± 20%, Maximum Withstand Current = 5 KA.
CE Conformity	These transmitters conform with the protection requirements of European Council Directives: 89/336/EEC, the EMC Directive and 1999/5/EC, the Telecommunications Directive per EN 300 328, V1.6.1 (2004-11), EN 300 489-1, V1.6.1 (2005-09), EN 300 489-3, V1.4.1 (2002-08) and EN 61326-1997+A1+A2, Electrical Equipment for Measurement, Control and Laboratory Use – EMC Requirements.
Hazardous Location Certifications	See the Model Selection Guide on page 7.

- Performance specifications are based on reference conditions of 25°C (77°F), zero (0) static pressure, and 10 to 55% RH.

Physical Specifications

Parameter	Description
Mounting Bracket	Carbon Steel (Zinc-plated) or Stainless Steel angle bracket or Carbon Steel flat bracket available (standard options).
Terminal Assembly wiring gauge range	28 to 16
Electronic Housing Stainless Steel Housing (option)	Epoxy-Polyester hybrid paint. Low Copper-Aluminum. Meets NEMA 4X (hosedown and corrosion resistant), IP 66/67 (hosedown and submersible to 1m). 316 SS Electronics Housing - with M20 Conduit Connections 316 SS Housing with 1/2" NPT Conduit Connection 316 SS or Grade CF8M, the casting equivalent of 316 SS with M20 or 1/2" NPT Conduit Connection. If ordered with the Remote Antenna options, the antenna parts are not SS or Marine type cables; the integral antenna uses SS parts.
Mounting	Can be mounted in virtually any position using the standard mounting bracket. Mounting should result in the antenna being vertically oriented. Bracket is designed to mount on 2-inch (50 mm) vertical or horizontal pipe. See Figure 3.
Dimensions	See Figure 4.
Net Weight	Approximately 9 pounds (4.1 Kg)

Wiring

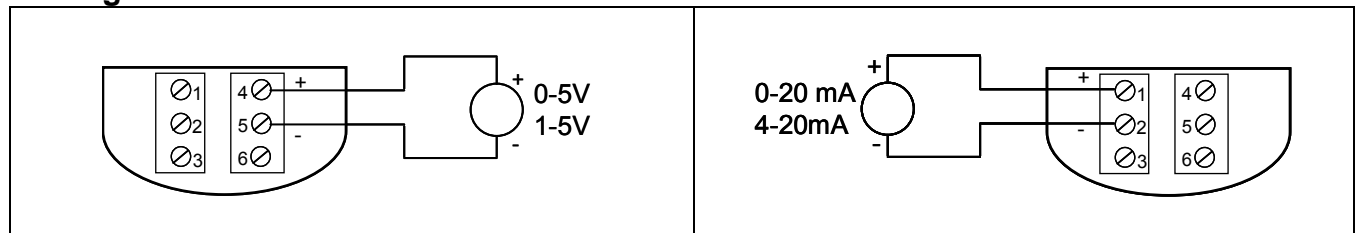

Figure 1 - Wiring: voltage (left), current (right)

Mounting

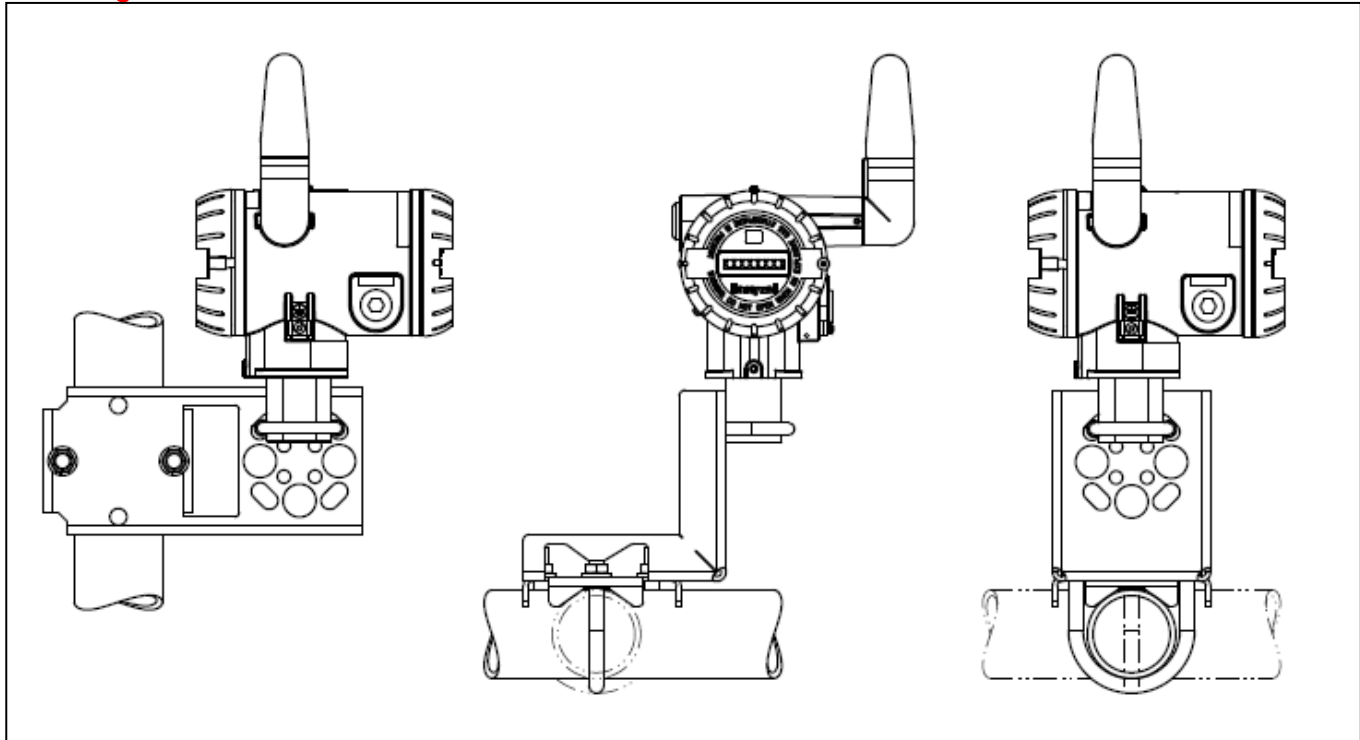

Figure 3—Examples of typical mounting positions

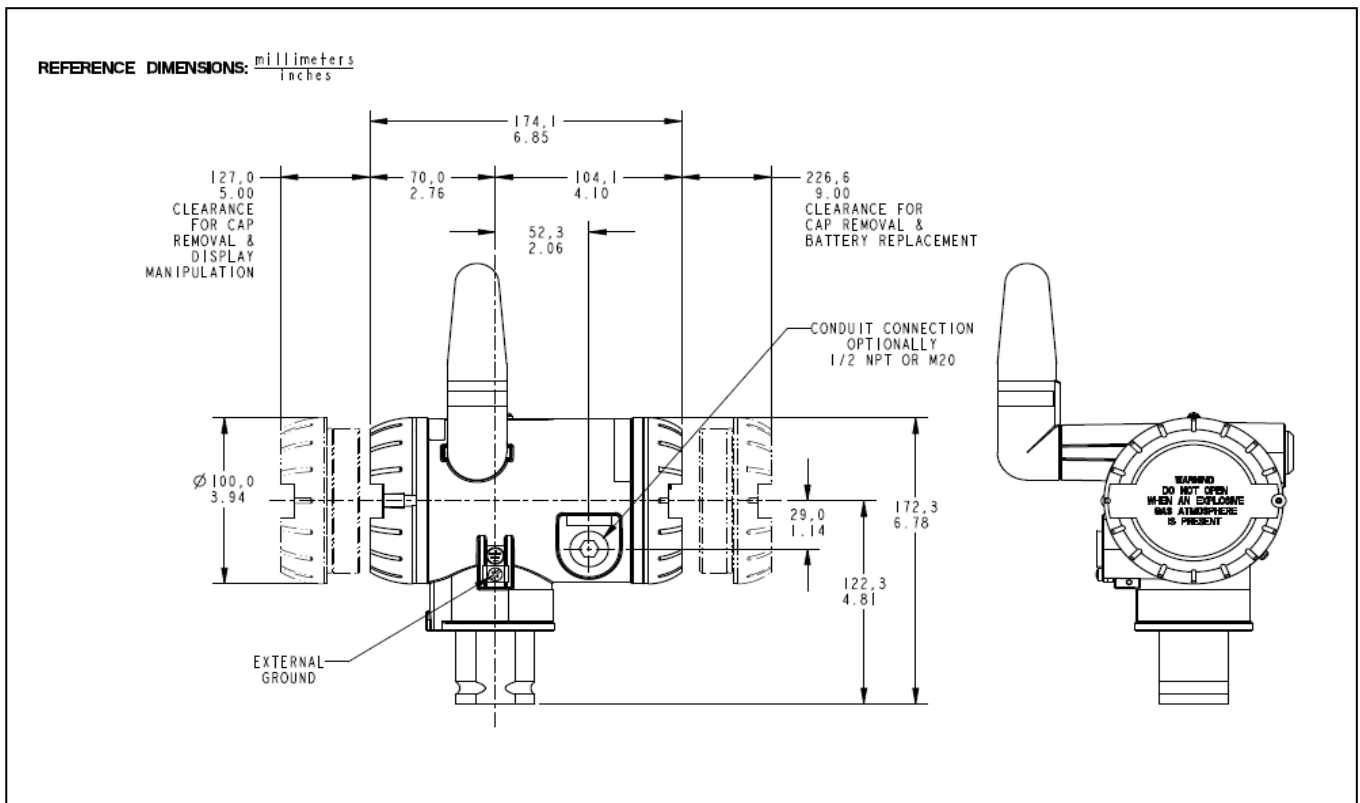

Figure 4—Typical mounting dimensions for reference.

Options

Mounting Bracket

The angle mounting bracket is available in either zinc-plated carbon steel or stainless steel and is suitable for horizontal or vertical mounting on a two inch (50 millimeter) pipe, as well as wall mounting. An optional flat mounting bracket is also available in carbon steel for two inch (50 millimeter) pipe mounting.

Tagging (Option TG)

Up to 30 characters can be added on the stainless steel nameplate mounted on the transmitter's electronics housing at no extra cost. A stainless steel wired on tag with additional data of up to 4 lines of 28 characters is also available. The number of characters for tagging includes spaces.

Transmitter Configuration

All configurable parameters are accessible via the OneWireless network via READ/WRITE transactions.

Ordering Information

Contact your nearest Honeywell sales office, or

In the U.S.:

Honeywell
Process Solutions
1860 West Rose Garden Lane
Phoenix, AZ 85053
1-800-423-9883

In Canada:

The Honeywell Centre
155 Gordon Baker Rd.
North York, Ontario M2H 3N7
1-800-461-0013

In Latin America:

Honeywell Inc.
480 Sawgrass Corporate Parkway,
Suite 200
Sunrise, FL 33325
(954) 845-2600

In Europe and Africa:

Honeywell S. A.
Avenue du Bourget 1
1140 Brussels, Belgium

In Eastern Europe:

Honeywell Praha,
s.r.o. Budejovicka 1
140 21 Prague 4,
Czech Republic

In the Middle East:

Honeywell Middle East Ltd.
Khalifa Street,
Sheikh Faisal Building
Abu Dhabi, U. A. E.

In Asia:

Honeywell Asia Pacific Inc.
Honeywell Building,
17 Changi Business Park Central 1
Singapore 486073
Republic of Singapore

In the Pacific:

Honeywell Pty Ltd.
5 Thomas Holt Drive
North Ryde NSW Australia 2113
(61 2) 9353 7000

In Japan:

Honeywell K.K.
14-6 Shibaura 1-chrome
Minato-ku, Tokyo, Japan 105-0023

Or, visit Honeywell on the World Wide Web at: www.honeywell.com/ps

Specifications are subject to change without notice.

Model Selection Guides are subject to change and are inserted into the specifications as guidance only. Prior to specifying or ordering a model check for the latest revision Model Selection Guides which are published at: <http://hpsweb.honeywell.com/Cultures/en-US/Products/Instrumentation/ProductModelSelectionGuides/default.htm>

Model Selection Guide (34-XY-16-47)



34-XY-16U-47
Issue 14
Page 1 of 3

XYR 6000 Wireless Transmitter High Level Input Interface Series 600

Model Selection Guide

Instructions

- Select the desired Key Number. The arrow to the right marks the selection available.
 - Make one selection from each Table, I and II.
 - Select as many Table III options as desired (if no options or approvals are desired, specify 9X).
 - A (♦) denotes unrestricted availability. A letter denotes restricted availability.
 - Restrictions follow Table V.
- Key Number I II III IV V
- _____ - 000 - 0000 - _____ - _____ - _____



Key Number	Description	Selection	Availability
* Wireless Analog Input Interface (0/1 to 5 and 0/4-20 mA)		STIW600	↓

* Only 0/4 to 20 mA input is certified as Intrinsically Safe. 0/1 to 5V input is not certified as Intrinsically Safe.

TABLE I - Options

Future		000	♦
--------	--	-----	---

TABLE II Options

Future		0000	♦
--------	--	------	---

TABLE III - ANTENNA OPTIONS

Antennas	Integral Right-angle, vertical 2dBi	V _____	d
	Integral Straight, horizontal 2dBi	S _____	d
	Integral Right-angle, vertical 4dBi	R _____	d
	Remote Omnidirectional, 8 dBi	M _____	p
	Remote Directional, 14 dBi	D _____	e
	Remote Antenna Adapter, Type N Connection	A _____	d
Cable A for Remote Antenna	None	_ 0 0 _	♦
	1.0m remote Cable A, Type TNC (Req'd to connect to XYR 6000)	_ 0 1 _	f
	3.0m remote Cable A, Type TNC (Req'd to connect to XYR 6000)	_ 0 3 _	f
	10.0m remote Cable A, Type TNC (Req'd to connect to XYR 6000)	_ 1 0 _	f
	1.0m remote Cable A, Type N (Req'd to connect to XYR 6000)	_ 2 1 _	k
	3.0m remote Cable A, Type N (Req'd to connect to XYR 6000)	_ 2 3 _	k
Cable B for Remote Antenna w/Accessories*	None	___ 0 0	♦
	Accessory + 1.0m Cable B to Antenna, N - N	___ 0 1	♦
	Accessory + 3.0m Cable B to Antenna, N - N	___ 0 3	♦
	Accessory + 10.0m Cable B to Antenna, N - N	___ 1 0	♦

* See Supplemental Accessories

TABLE IV - OPTIONS

Radio Options		(Must Choose a Radio Option)		
2.4 GHz Frequency Hopping Spread Spectrum (FHSS)	XF	•	b	
2.4 GHz Direct Sequence Spread Spectrum (802.15.4 DSSS)	XD	•		
ISA 100.11a Compliant (2.4 GHz Direct Sequence Spread Spectrum 802.15.4 DSSS-FH)	XS	•		
Power Option		(Must Choose Power Option)		
Battery Holder Only - No Battery Included	00	•	b	
Battery Power	BA	•		
24VDC	DC	•		
Transmitter Housing & Electronics Options				
M20 Conduit Thread (1/2" NPT is standard)	A1	f	b	
1/2" NPT to 3/4" NPT 316 SS Conduit Adapter	A2	g		
1/2" NPT to 3/4" NPT 316 SS Conduit Adapter (Quantity of 2 for 24VDC Option)	A4	h		
316 SS ^{1,2} Electronics Housing - with M20 Conduit Connections	SH	•	b	
316 SS ^{1,2} Housing with 1/2" NPT Conduit Connection	A3	•		
Stainless Steel Customer Wired-On Tag (4 lines, 28 characters per line, customer supplied information)	TG	•	b	
Stainless Steel Customer Wired-On Tag (blank)	TB	•		
End Cap Warning Label in Spanish	SP	•	b	
End Cap Warning Label in Portuguese	PG	•		
End Cap Warning Label in Italian	TL	•		
End Cap-Warning Label in German	GE	•		
Transmitter Mounting Brackets Options				
Mounting Bracket - Carbon Steel	MB	•	b	
Mounting Bracket - 304 SS	SB	•		
Flat Mounting Bracket - Carbon Steel	FB	•		
Services/Calibration/Conformance Options				
User's Manual Paper Copy	UM	•	b	
Calibration Test Report and Certificate of Conformance (F3399)	F1	•		
Certificate of Conformance (F3391)	F3	•		
Certificate Options				
Certificate of Origin (F0195)	F5	•		
Warranty Options				
Additional Warranty - 1 year	W1	•	b	
Additional Warranty - 2 years	W2	•		

¹ Supplied as 316 SS or as Grade CF8M, the casting equivalent of 316 SS.

² If ordered with Remote Antenna option, Table III Selection M _____ or D _____, antenna parts are not SS or Marine type cables

STIW600

Selection

TABLE IV - OPTIONS (continued)

Approval Body	Approval Type	Location or Classification		
No hazardous location approvals			9X	•
FM	Intrinsically Safe	Class I, II, III, Div. 1, Groups A,B,C,D,E,F,G; T4, Ta ≤ 85°C; Type 4X Class I, AEx ia IIC; T4, Ta ≤ 85°C, Zone 0; IP66	1C	•
	Explosion-proof	Class I, Div. 1, Groups A,B,C,D; Cl II, Div. 1, Groups E, F & G; Cl III, Div. 1, T4, Ta ≤ 85°C; Type 4X Class I, AEx d IIC; T4, Ta ≤ 85°C, Zone 1; IP66		
	Nonincendive	Class I, Div. 2, Groups A,B,C,D; T4, Ta ≤ 85°C; Type 4X		
	Non-Sparking	Class I, AEx nA IIC; T4, Ta ≤ 85°C, Zone 2; IP66		
CSA cus	Nonincendive	Nonincendive, CL I, Div 2, Groups A,B,C & D, CL II & III, Div 2, Groups F & G, T4 Ta = 85°C	2N	•
	Non-Sparking	Class I, Ex/AEx nA IIC; T4, Ta ≤ 85°C, Zone 2; IP66		
	Intrinsically Safe	Class I, Div. 1, Gp A,B,C,D; Class II, Div 1, Gp E,F,G; Class III, Div 1; T4, Ta ≤ 85°C; Type 4X Class I, Ex/AEx ia IIC; T4, Ta ≤ 85°C, Zone 0; IP66	2C	•
	Explosion-proof	Class I, Div. 1, Groups A,B,C,D; Class II, Div. 1, Groups E, F & G; Class III, Div. 1, T4, Ta ≤ 85°C; Type 4X Class I, Ex/AEx d IIC; T4, Ta ≤ 85°C, Zone 1; IP66		
	Nonincendive	Class I, Div. 2, Groups A,B,C,D; T4, Ta ≤ 85°C; Type 4X		
Non-Sparking	Class I, Ex/AEx nA IIC; T4, Ta ≤ 85°C, Zone 2; IP66			
ATEX	Intrinsically Safe	II 1 GD; Ex ia IIB; T4, Ta ≤ 70°C, Zone 0; IP66 Ex tD A20 IP66 T90°C	3U	•
	Flameproof	II 2 GD; Ex d [ia] IIB; T4, Ta ≤ 70°C, Zone 1; IP66 Ex tD A21 IP66 T90°C	3B	•
	Non-Sparking	II 3 GD; Ex nA [nL] IIC; T4, Ta ≤ 84°C, Zone 2 Ex tD A22 IP66 T90°C	3Y	•
	Intrinsically Safe	II 1 GD; Ex ia IIB; T4, Ta ≤ 70°C, Zone 0; IP66 Ex tD A20 IP66 T90°C	3C*	•
	Flameproof	II 2 GD; Ex d [ia] IIB; T4, Ta ≤ 70°C, Zone 1; IP66 Ex tD A21 IP66 T90°C		
	Non-Sparking	II 3 GD; Ex nA [nL] IIC; T4, Ta ≤ 84°C, Zone 2 Ex tD A22 IP66 T90°C		
IECEX Australia & New Zealand	Intrinsically Safe	Ex ia IIB; T4, Ta ≤ 70°C, Zone 0; IP66 Ex tD A20 IP66 T90°C	CU	•
	Flameproof	Ex d [ia] IIB; T4, Ta ≤ 70°C, Zone 1; IP66 Ex tD A21 IP66 T90°C	CB	•
	Non-Sparking	Ex nA [nL] IIC; T4, Ta ≤ 84°C, Zone 2; IP66 Ex tD A22 IP66 T90°C	CY	•
	Intrinsically Safe	Ex ia IIB; T4, Ta ≤ 70°C, Zone 0; IP66 Ex tD A20 IP66 T90°C	C1*	•
	Flameproof	Ex d [ia] IIB; T4, Ta ≤ 70°C, Zone 1; IP66 Ex tD A21 IP66 T90°C		
Non-Sparking	Ex nA [nL] IIC; T4, Ta ≤ 84°C, Zone 2; IP66 Ex tD A22 IP66 T90°C			
SAEx South Africa	Intrinsically Safe	Ex ia IIB; T4, Ta ≤ 70°C, Zone 0; IP66 Ex tD A20 IP66 T90°C	ZU	•
	Flameproof	Ex d [ia] IIB; T4, Ta ≤ 70°C, Zone 1; IP66 Ex tD A21 IP66 T90°C	ZB	•
	Non-Sparking	Ex nA [nL] IIC; T4, Ta ≤ 84°C, Zone 2; IP66 Ex tD A22 IP66 T90°C	ZY	•
	Intrinsically Safe	Ex ia IIB; T4, Ta ≤ 70°C, Zone 0; IP66 Ex tD A20 IP66 T90°C	ZC*	•
	Flameproof	Ex d [ia] IIB; T4, Ta ≤ 70°C, Zone 1; IP66 Ex tD A21 IP66 T90°C		
	Non-Sparking	Ex nA [nL] IIC; T4, Ta ≤ 84°C, Zone 2; IP66 Ex tD A22 IP66 T90°C		
INMETRO Brazil	Intrinsically Safe	Ex ia IIC; T4, Ta ≤ 85°C, Zone 0; IP 66	6C*	
	Flameproof	Ex d IIC; T4, Ta ≤ 85°C, Zone 1; IP 66		
	Non-Sparking	Ex nA IIC; T4, Ta ≤ 85°C, Zone 2; IP 66		

* The user must determine the type of protection required for installation of the equipment. The user shall then check the box [v] adjacent to the type of protection used on the equipment certification nameplate. Once a type of protection has been checked on the nameplate, subsequently the equipment shall not be reinstalled using any of the other certification types.

WARNING – Division 2 / Zone 2 apparatus may only be connected to processes classified as non-hazardous or Division 2 / Zone 2. Connection to hazardous (flammable or ignition capable) Division 1 / Zone 0, or 1 process is not permitted.

TABLE V

Country	(Must Choose a Country Code)	Country Code	Availability	
North America, Canada		NA00	•	b
European Union		EU00	•	
Japan		JP00	m	

RESTRICTIONS

Restriction Letter	Available Only With		Not Available With	
	Table	Selection	Table	Selection
b	Select only one option from this group			
d	III	00 , 00		
e			III	00
f			IV	SH, A3
g			IV	DC, SH, A1
h			IV	BA, SH, A1
k	IV	SH, A3		
m	IV	9X		
p			V	JP00

Note: To request a quotation for a non-published "special", fax RFQ to 602 313-6155.

34-XY-16U-47
Issue 14
Page 3 of 3

Supplemental Accessories & Kits

Description	Part Number
1/2 NPT Socket Plug (ZN Plated CS)	50021832-001
1/2 NPT Certified Conduit Plug (SS)	50021832-002
M20 Certified Conduit Plug (SS)	50000547-001
M20 Conduit Plug (ZN Plated CS)	50000547-002
Surge Diverter*	50018279-090
Lithium Thionyl Chloride Batteries (Qty 2)	50026010-501
Lithium Thionyl Chloride Batteries (Qty 4)	50026010-502
Lithium Thionyl Chloride Batteries (Qty 10)	50026010-503

* Surge Diverter Accessory supplied with Table III, Selections XXX01, XXX03, XXX10

OneWireless and XYR are trademarks and Experion is a registered trademark of Honeywell International Inc.

Honeywell

Honeywell Field Solutions

1860 West Rose Garden Lane

Phoenix, Arizona 85027

Tel: 1-800-423-9883

www.honeywell.com/ps/hfs

34-XY-03-30

November 2010

© 2009-10 Honeywell International Inc.
